

Silvaflame-Cleervue Co Ltd

LATHE LEADSCREW COVERS

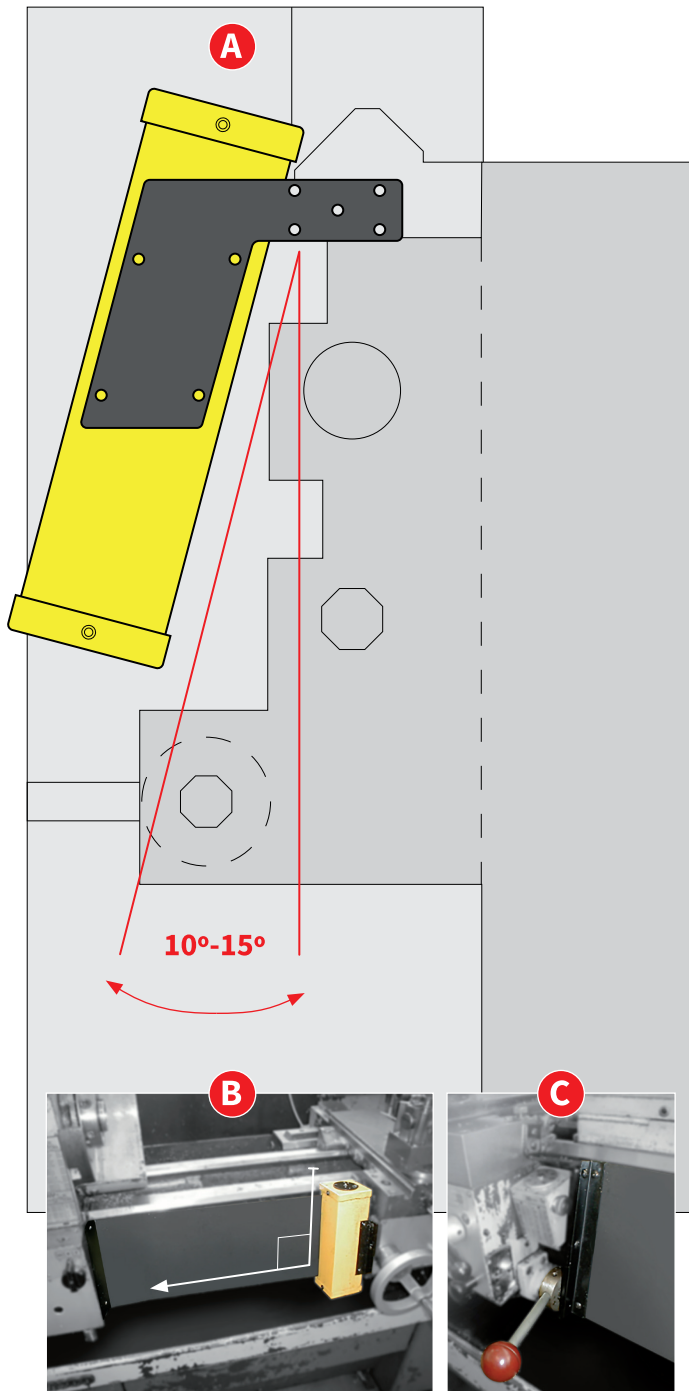

GENERAL FITTING INSTRUCTIONS

2 Common Brackets are Supplied, however due to the complex design of Lathes, other Brackets may need 'In-House-Manufacture'.

IMPORTANT: THE UNIT MUST BE AT A 10°-15° ANGLE away from the machine and the **TOP OF THE BRACKET MUST BE HORIZONTAL - A**

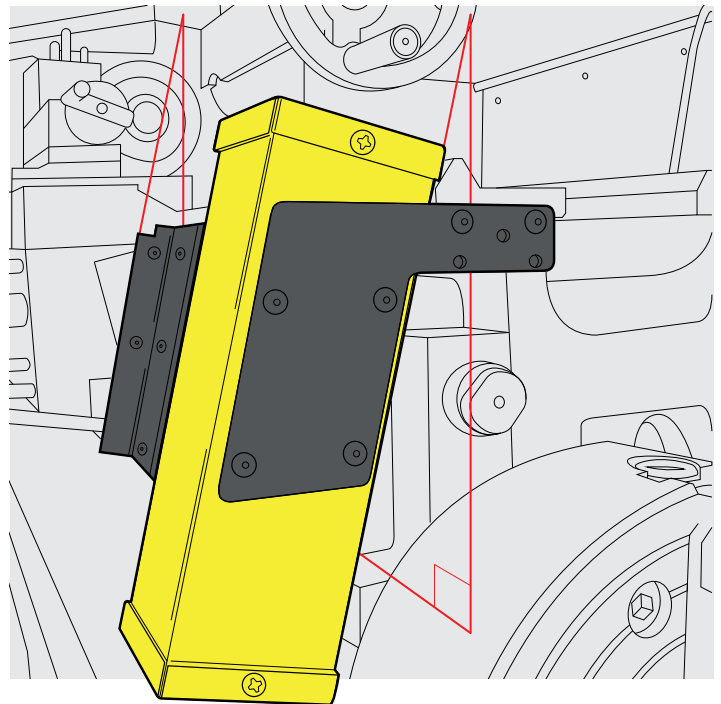

IT IS CRITICAL that the box is vertical & that the edge of the material is just touching the point at the bottom of the inverted V on the bed and it runs horizontally along the bed at right-angles to the box - **B**

IT IS IMPERATIVE that the bracket allows full movement of any control lever - **C**

Long Beds (3 Blind System) Gear Driven Tail-Stock

- Blind 1 - Between Head-Stock and Saddle
- Blind 2 - Between Saddle and Tail-Stock
- Blind 3 - Between Tail-Stock and End-of-Bed

SILVAFLAME-CLEERVUE COMPANY LIMITED

22, Park Street, Bridgtown, Cannock, Staffordshire, WS11 0BX. UK

T: **01543 431060** F: **01543 509140**

e-mail: enquiries@silvaflame.com / silvaflame@cleervue.com

Manufacturers of MACHINERY SAFETY GUARDS



British made for
over 70 years

